



# Airline Travel Card

User Name:  
 User Phone:  
 User Email:  
 Serial Number:

## USER:

- 1 Power OFF in Standard Mode.
- 2 Remove User Controller. Store your user controller in carry-on luggage. Removing the user controller isolates battery power.
- 3 Remove Cushion. Fold Seat Forward. Raise Foot Supports. Removing the cushion is optional.
- 4 Install Travel Cover (Optional)
- 5 Attach Travel Card to the Device or Insert into Travel Cover

## AIRLINE:

- 1 Unlock the Brake. Turn the Freewheel Lever to the Unlock position.
- 2 Push the Device to Location.
- 3 Lock Brake and Lift Device. Turn the Freewheel Lever to the Lock position. With more than one person, manually lift from the rear drive wheels and front caster arms as indicated by the lift point labels.
- 4 On Aircraft, Secure Device with Tie-downs. The iBOT® PMD must be locked into position by running tie-down straps through the securement points at the front and rear, as indicated by securement labels.

## Travel Configuration

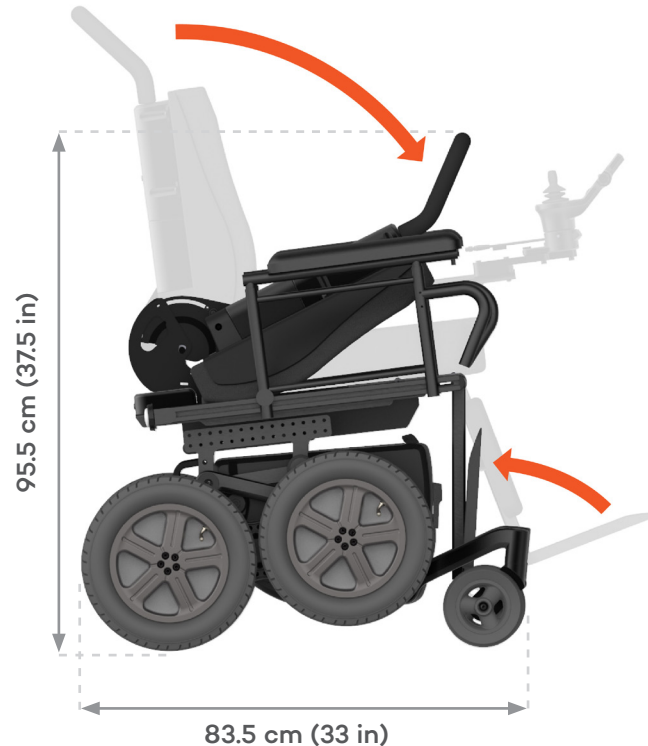

**Unoccupied Product Weight**  
**122 kg (269 lb)**



**Weight of Additional Components**  
 (if greater than 10 kg)

\_\_\_\_\_ kg \_\_\_\_\_ (lb)

## Driving Configuration

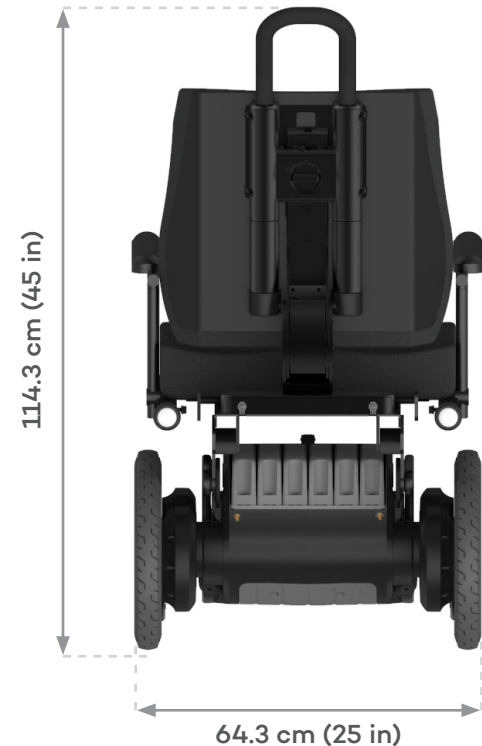

## Battery Information

**WARNING:** Only batteries intended for use with the iBOT® PMD and provided by Mobius Mobility may be installed on this product.

This wheelchair is manufactured with 4 or 6, 288 Wh Lithium-ion batteries. The batteries are not designed to be removed for air travel.

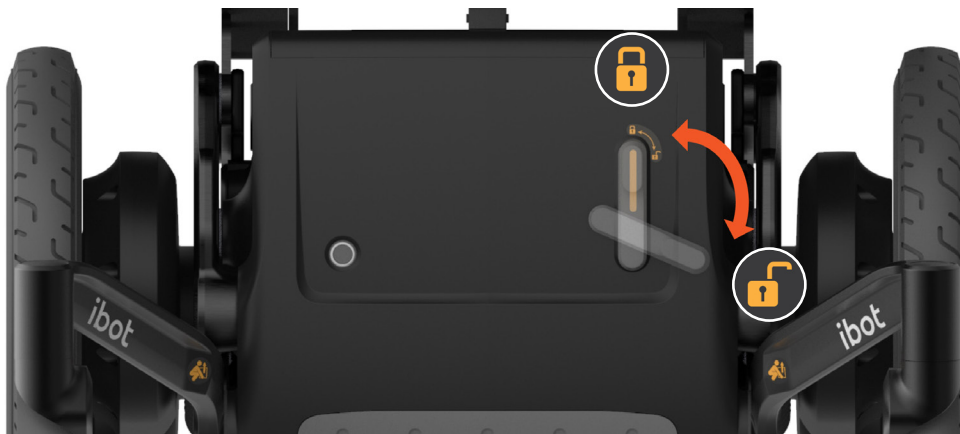
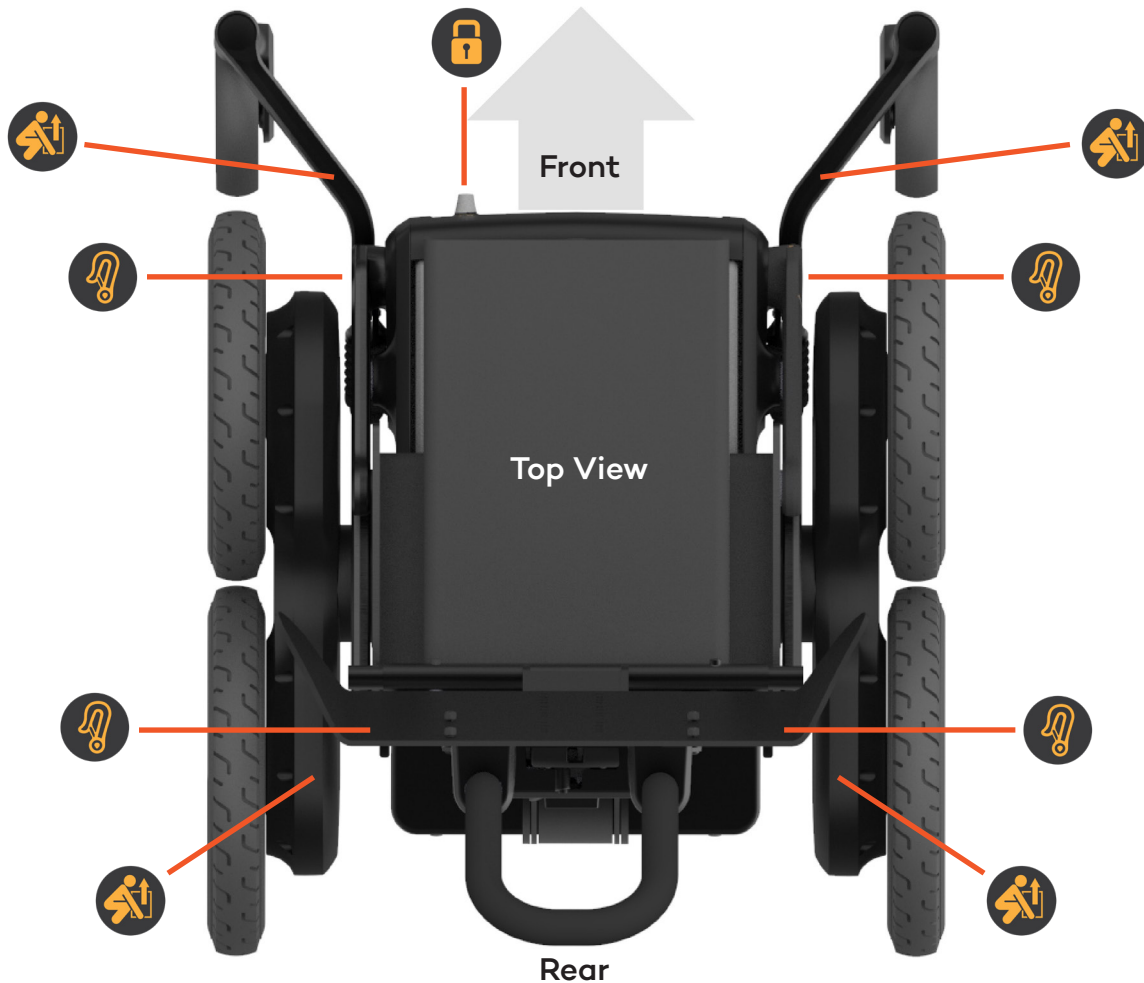

### Isolate Battery Power

Removing the user controller isolates battery power. User stores the user controller in their carry on luggage.



### Unlock Brake

The Freewheel Lever is located on the front of the powerbase. Turning the Freewheel Lever to the unlocked position disengages the drive system making it possible to move the chair manually.



### Manual Lift Points

The iBOT® PMD unoccupied weight is 122 kg (269 lb). With more than one person, manually lift the device from the rear drive wheels and the front caster arms as indicated by the lift point labels.



### Chair Securement

The iBOT® PMD must be secured in position by running tie-down straps through the securement points located at the front and rear, marked with the securement labels.



### Lock Brake

Lock the brake by turning the Freewheel Lever to the lock position.

### iBOT® Technical Support:

1-833-3GO-IBOT

(1-833-346-4268)

service@mobiusmobility.com